

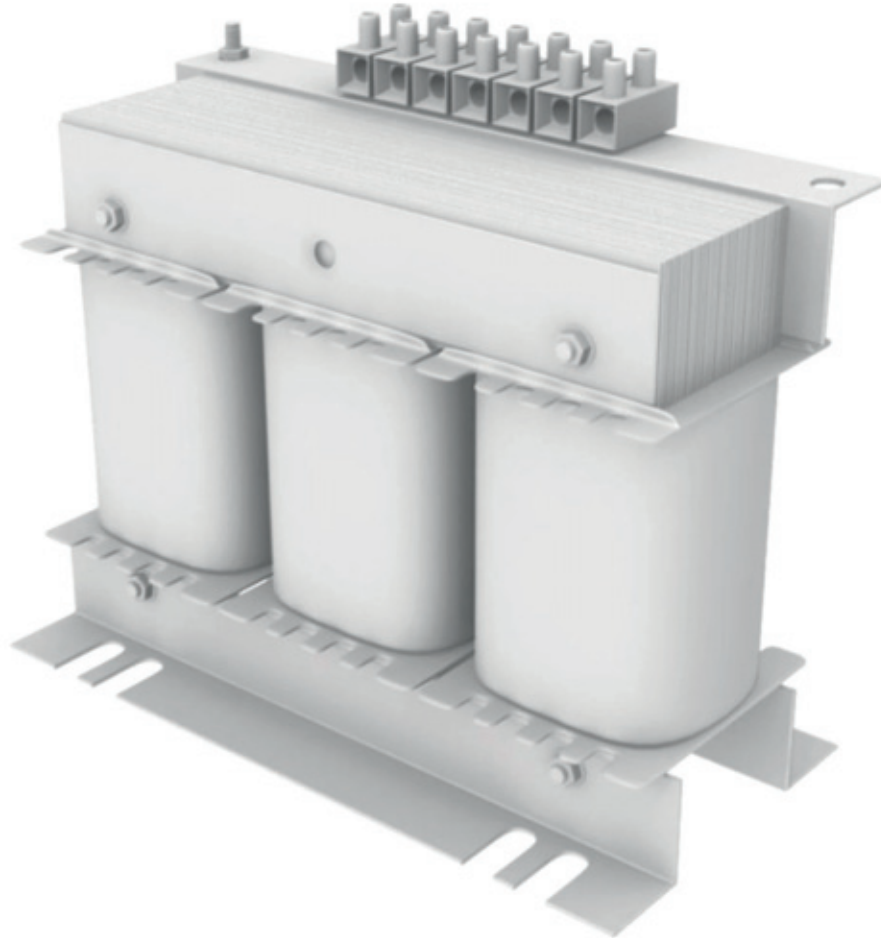

ROYAL DIAMOND

your insulation partner



Dry Type Transformer

We design, formulate and costumize resins, varnishes and flexible laminates
for Dry Type Transformer

Our wide experience reached after all this time being close to our clients (PARTNERS) in Transformer Market allows us to design and develop systems of electrical insulation for any industrial sectors.

Dry Type Transformer

Transformers like Autotransformers, Inductances, Three-phase and Toroidal type need an electrical insulation system with the following properties:

- High dielectric strength and electrical insulation
- Good heat dissipation
- Resistance to external elements (changes in temperature, humidity, oil, dust, etc.)
- Maximum use for adaptation to the design and mechanical construction of the systems
- Chemical and mechanical resistance

Royal Diamond designs and manufactures a wide range of products which offer all of these properties and the following functions :

- Insulation between phases and coils with flexible insulating laminates
- Protection by impregnation and finishing varnishes and resins
- Protection by potting and filling resins
- Adhesive tapes

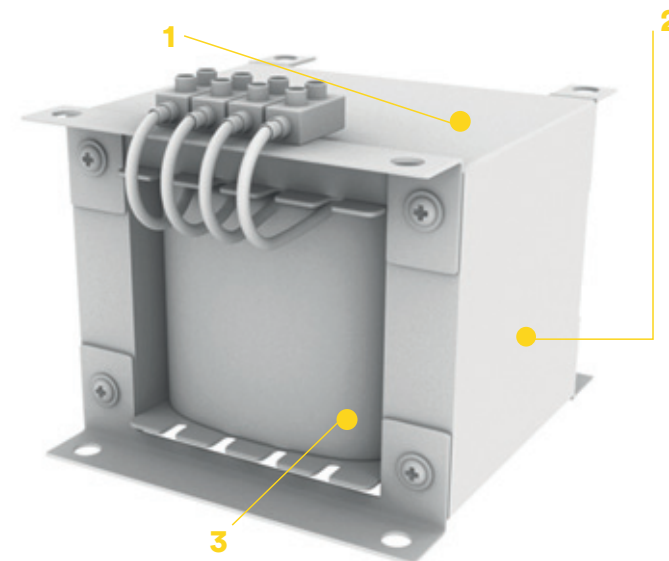

1. Varnish and resin for impregnation
2. Potting resin
3. Flexible Laminates

RESINS

| | Product | Chemical Nature | Thermal Class | Drying Method |
|----------------------------------|-----------------------------------|-----------------------|---------------|---------------|
| ENCAPSULATION AND FILLING | DIAPOL 507 | POLYURETHANE | B (130°C) | AIR |
| | DIAPOL 508 | POLYURETHANE | B (130°C) | AIR |
| | DIAPOL 509 | POLYURETHANE | B (130°C) | AIR |
| | DIAPOL 509FG AUTOEXTINGUIBLE (UL) | POLYURETHANE | B (130°C) | AIR |
| | ROYAPOX 5050CD | EPOXY | B (130°C) | AIR |
| | ROYAPOX 959 (UL) | EPOXY | B (130°C) | AIR |
| | ROYAPOX 502F (UL) | EPOXY | H (180°C) | OVEN |
| | ROYAPOX 502FC | EPOXY | H (180°C) | OVEN |
| IMPREGNATION | ROYAPOX 511 | EPOXY | F (155°C) | AIR |
| | ROYAPOX 915 | EPOXY SOLVENTLESS | H (180°C) | OVEN |
| | DIAPOL 790SL (UL) | POLYESTER SOLVENTLESS | H (180°C) | OVEN |
| | DIAPOL 788/200 | POLYESTERIMIDE | N (200°C) | OVEN |

VARNISHES

| | Product | Chemical Nature | Thermal Class | Drying Method | Base |
|------------------------------|----------------------|---------------------|---------------|---------------|---------|
| IMPREGNATION | ROYALAC 30 | ALKYDIC | B (130°C) | AIR | SOLVENT |
| | ROYALAC 129 | URETHANIC | F (155°C) | AIR | SOLVENT |
| | ROYALAC 158/4 | UREA / FORMALDEHYDE | F (155°C) | OVEN | SOLVENT |
| | ROYALAC 521 | ALKYDIC/EPOXY | F (155°C) | OVEN | SOLVENT |
| | ROYALAC 525MA | ALKYDIC/EPOXY | H (180°C) | OVEN | SOLVENT |
| | E-524TS (UL) | ALKYDIC/EPOXY | H (180°C) | OVEN | SOLVENT |
| | WE203 (UL) | ALKYDIC | H (180°C) | OVEN | WATER |
| FINISH AND PROTECTION | ANTIFLASH G-142 (UL) | ALKYDIC/EPOXY | F (155°C) | OVEN | SOLVENT |
| | ANTIFLASH G-144 (UL) | ALKYDIC | F (155°C) | AIR | SOLVENT |
| | ANTIFLASH 505 (UL) | EPOXY | H (180°C) | AIR | SOLVENT |
| | ANTIFLASH 214SR (UL) | ALKYDIC/SILICONE | H (180°C) | AIR/OVEN | SOLVENT |

FLEXIBLE LAMINATES

| | Product | Material | Thermal Class | Thickness |
|------------------------|----------------------|-----------------|-----------------|-----------------------|
| NOT IMPREGNATED | POLYESTER FILM | POLYESTER | B (130°C) | From 0,023 to 0,35 mm |
| | TERCOTT MTS (UL) | DMD | B/F (130/155°C) | From 0,11 to 0,45 mm |
| | TUFQUIN TFT (UL) | TUFQUIN BASED | H (180°C) | From 0,13 to 0,51 mm |
| | THERNOMID AFA (UL) | ARAMIDE BASED | H (180°C) | From 0,14 to 0,47 mm |
| | TUFQUIN TPiT (UL) | TUFQUIN BASED | N (200°C) | From 0,12 to 0,32 mm |
| | THERNOMID APiA (UL) | ARAMIDE BASED | N (200°C) | From 0,13 to 0,30 mm |
| IMPREGNATION | THERNOMID 10.04VF | DM IMPREGNATED | F (155°C) | From 0,06 to 0,30 mm |
| | TRIPLEX F 20.08 (UL) | DMD IMPREGNATED | F (155°C) | From 0,13 to 0,45 mm |



ROYAL DIAMOND
your insulation partner

Our values:

Tradition

More than 60 years dedicated to electrical insulation for different sectors. A combination of values, experience and know-how make us your best partner for your electrical insulation needs.

Customization

We understand electrical insulation like a system integrated of resins, varnishes and flexible laminates as individually designed for any sector and Client.

Human Team

Our Team is made up of more than 50 people who transmit naturally the values of the company.

Quality

The quality in our company and our products is a must and we work under ISO 9001:2015 certification.

Our target is to be your best **partner** to create great projects together.

Camí del Cementiri, 2 (Pol. Ind. Can Ribot) | 08319 Dosrius (Barcelona) España
T: +34 937 918 006 | e-mail: royaldiamond@royal-insulation.com

Pirineos, 515 Int. 47 (Parque Industrial Benito Juárez) | 76120 Querétaro (QRO.) México
T: +52 442 209 5172 | e-mail: mexico@royal-insulation.com

www.royal-insulation.com